

Jackfish Spectroelectrochemical Cell – For Surface-Sensitive Electrochemical ATR-SEIRAS



FEATURES

- Teflon® and glass design offer excellent compatibility with organic solvents and acidic/basic media
- Reliable electrical contact with Au thin-film electrode
- Dedicated ports for gas bubblers, counter and reference electrodes and exhaust gas trap
- Easy installation on the VeeMAX III ATR accessory
- Two versions available to accommodate VeeMAX ATR crystals or ATR Se wafers

The Jackfish Spectroelectrochemical Cell (SEC) enables fundamental studies of the electrified metal-solution interface and applications in molecular self-assembly, interfacial sensing, and next-generation energy solutions. It is designed for surface-sensitive FTIR spectroelectrochemistry using the attenuated total reflectance surface-enhanced infrared spectroscopy (ATR-SEIRAS) technique. High-quality IR spectra can be obtained from sub-monolayer amounts of adsorbed molecules. By controlling the electrical potential applied to the Au thin film electrode on the ATR crystal surface, the user can perform vibrational characterization of potential-dependent changes at the interface.

By design, the cell is fully compatible with the PIKE VeeMAX III variable angle ATR sampling accessory. Two versions are available to provide maximum flexibility to the end-user. The J1 is designed around the PIKE Si face-angled crystal (FAC). In a previous study investigating the adsorption of a pyridine derivative, the spectral response was two times stronger when using a Si 60 degree FAC compared to a Si hemisphere with an angle of incidence of 65 degrees. Additionally, the FAC exhibited higher energy throughput and lower spectral noise above the long-wavelength cutoff. The J1W accommodates an IRUBIS GmbH single reflection microgrooved Si

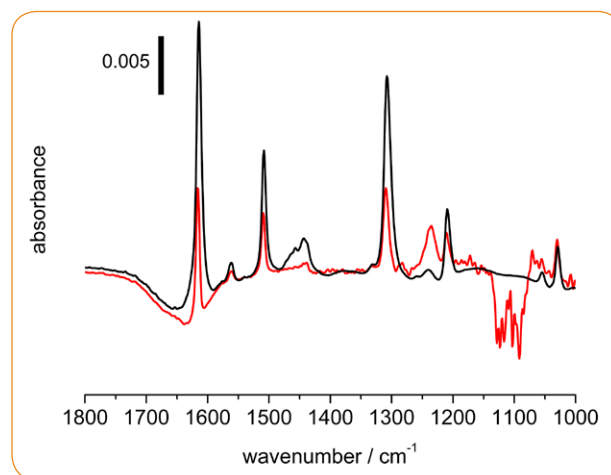

Comparison of electrochemical ATR-SEIRAS response with the VeeMAX III Si 60 degree FAC (black) and a Si hemisphere (red). The sample spectrum is of the Au thin film electrode covered in a monolayer of adsorbed pyridine derivative at positive potential; the reference spectrum is taken at negative potential where the pyridine is completely desorbed.

wafer. The shorter pathlength, relative to FAC, of the beam through the wafer mitigates absorption losses due to Si phonon absorption, allowing the user complete access to the fingerprint and far-IR spectral regions. Wafers are inexpensive and can be recycled or disposed depending on the application.

The Jackfish SEC is constructed from highly chemical-resistant Teflon and glass for a broad range of aqueous or organic solution conditions. There are three ports at the top of the cell and side ports for a reference electrode arm and a short bubbler. Typical uses of the ports are to support the counter electrode, and to accommodate a long glass bubbler and an exhaust gas trap. The long glass bubbler allows sparging of the solution volume with inert gas to remove atmospheric oxygen, enabling high-quality electrochemistry and ensuring stability of the Au thin film electrode. The short gas bubbler is used to create an inert atmosphere above the electrolyte. Ground glass joints ensure the cell remains sealed from air. Connection to the working electrode is made easily using spring-loaded pins which contact the Au thin film electrode outside of the solution. This innovative design maintains superior electrical contact over long experiments without degrading the thin film electrode.

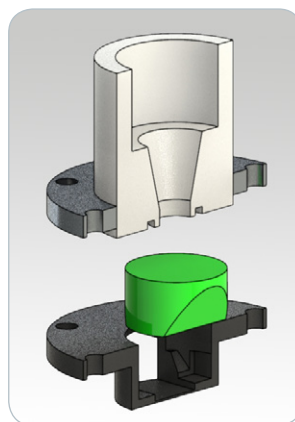

Jackfish model J1

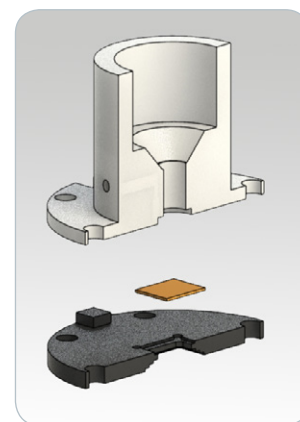

Jackfish model J1W

The crystal is fully removable for ease of metal coating. Coating may be performed using a vacuum chamber for sputter coating or through electroless deposition. For users performing electroless deposition, a convenient fixture is available to provide a crystal housing that allows the deposition solution to contact only the crystal top surface during the coating process. The cell is compatible with any of the four FAC materials listed below. However, the recommended material for either metal deposition process is Si due to its excellent chemical stability and favorable wetting characteristics with Au films.

ORDERING INFORMATION

PART NUMBER	DESCRIPTION
162-4710	Jackfish Spectroelectrochemical Cell
162-4715	Jackfish J1W SEC
162-4717	Jackfish SEC Combination Cell
013-11XX	VeeMAX III Variable Angle Specular Reflectance Accessory <i>Includes purge tubes, purge kit and spectrometer base mount.</i>

Notes: Replace **XX** with your spectrometer's Instrument Code. [Click for List >](#)
The VeeMAX III is required for use of the Jackfish Spectroelectrochemical Cell.

CRYSTAL OPTIONS (choose at least one)

PART NUMBER	DESCRIPTION
160-5552	Si Crystal, 60°
160-5550	ZnSe Crystal, 60°
160-5553	ZnS Crystal, 60°
160-5551	Ge Crystal, 60°
162-4814	J1W Si ATR elements (2)

Note: The 60° Si crystal is the user-preferred option.

CUSTOM ELECTRODES FOR THE JACKFISH SPECTROELECTROCHEMICAL CELL

PART NUMBER	DESCRIPTION
162-4720	Platinum Counter Electrode
162-4722	Gold Counter Electrode
162-4723	Ag/AgCl Reference Electrode

Note: The Platinum Counter Electrode and Ag/AgCl Reference Electrode are the user-preferred options.

REPLACEMENT PARTS AND OPTIONS

PART NUMBER	DESCRIPTION
162-4724	Lower Viton® O-ring
162-4726	Upper Viton O-ring
162-4728	Lower Perfluoroelastomer O-ring
162-4730	Upper Perfluoroelastomer O-ring
162-4732	Electroless Deposition Fixture
162-4734	Reference Electrode Arm with Stopcock
162-4736	Jackfish SEC, Long Bubbler
162-4738	Jackfish SEC, Short Bubbler
162-4740	Jackfish SEC, Exhaust Gas Trap

Note: Please contact PIKE Technologies for parts not found here.

The cell includes

- Teflon body
- Glass cell body
- Glass cell cap with ports
- Glass cell cap without ports
- 4 glass stoppers
- Glass exhaust gas trap
- 2 glass long bubbler (1 spare)
- 2 glass short bubbler (1 spare)
- Glass reference arm with glass stopcock
- Glass counter electrode holder
- 6 Au-coated spring-loaded pins for electrical connection (3 spares)
- 6 #2-56 screws for electrical connection (3 spares)
- Aluminum ring (J1 only)
- 12 #8-32 screws for aluminum ring (6 spares)
- Delrin face angled crystal holder or wafer holder
- 4 Viton O-rings (2 spares)
- Adapter plate for VeeMAX III

The VeeMAX III and the ATR FAC or ATR Si wafer are ordered separately.

Jackfish SEC was founded in 2018 in Saskatoon, Canada by electrochemists at the University of Saskatchewan. The team has spent 10 years designing, innovating and testing spectroelectrochemical cells for attenuated total reflectance surface-enhanced infrared spectroscopy (ATR-SEIRAS). A decade of experiment-based design improvements have led to our innovative and commercially available ATR-SEIRAS cell design. We are dedicated to making advanced infrared spectroelectrochemical technology easily accessible to new users with off-the-shelf solutions that allow you to easily equip your laboratory with ATR-SEIRAS capabilities.

Selected References

Electrochemical ATR-SEIRAS Using Low-Cost, Micromachined Si Wafers. *Analytical Chemistry*, 2017, 89, 11818–11824.

Femtomole Infrared Spectroscopy at the Electrified Metal–Solution Interface. *Analytical Chemistry*, 2016, 88, 9351–9354.

Surface Enhanced Infrared Studies of 4-Methoxypyridine Adsorption on Gold Film Electrodes. *Langmuir*, 2016, 32, 2184–2191.

Surface Enhanced Infrared Spectroscopy and Neutron Reflectivity Studies of Ubiquinone in Hybrid Bilayer Membranes under Potential Control. *Langmuir*, 2016, 32, 2225–2235.

Charge Transfer and SEIRAS Studies of 1,4-Benzoquinone Functionalized Mixed Monothiol/Dithiol Self Assembled Monolayers. *Electrochimica Acta*, 2011, 56, 4361–4368.

Surface Enhanced Infrared Absorption Spectroscopy Studies of DMAP Adsorption on Gold Surfaces. *Langmuir*, 2009, 25, 2241–2247.